

Operator's Manual

METOR

Handheld Laser Receiver

MTR-125 LE

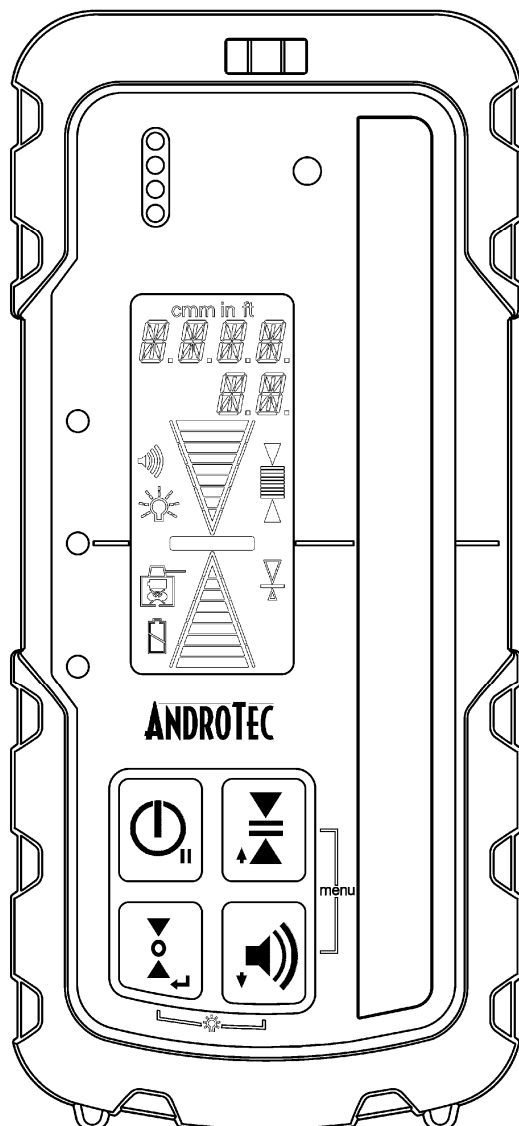

ANDROTEC

Thank you for purchasing AndroTec METOR LE. Your handheld laser receiver is a premium quality tool, which has been designed and manufactured to provide years of precise and reliable performance.

IMPORTANT: This manual is an important part of your purchase as it will familiarize you with the unit and explain the numerous features that have been designed into it. Please read this manual thoroughly before use.

Please contact your AndroTec dealer or AndroTec in case you have questions regarding specific applications or if you require additional information.

IMPORTANT: Fill out the warranty registration card and return it to AndroTec GmbH.

Please record your information below for future reference.

MODEL: _____

SERIAL NUMBER: _____

DATE OF PURCHASE: _____

PURCHASED FROM: _____

PHONE: _____

Table of Contents

1	Included in Delivery	2
2	General Description	3
3	Front View	4
4	Rear View	5
5	Installing the Batteries	6
6	Keypad	7
7	Secondary Key Functions	8
8	Display	9
9	Advanced Functions	13
10	Menu Functions	14
11	Rod Clamp	18
12	Specifications	19
13	Warranty	20
14	Maintenance and Safety	21
15	Disposal	22
16	CE Declaration of Conformity	23

1 Included in Delivery

- AndroTec METOR LE handheld laser receiver
- Rod clamp
- Two AA batteries
- Operator's manual
- Warranty registration card

Optional available accessoires:

- Bubble vial kit for rod clamp

2 General Description

AndroTec METOR LE is a handheld laser receiver, designed to receive and to display reference elevation information from red and infrared rotational lasers. A large 127mm vertical reception window captures the laser beam using AndroTec's patented X²L sensor technology.

Elevation information is output via two liquid crystal displays (LCDs, one in the front, one in the rear) and three bright LEDs in the front. A beeper additionally emits adjustable audible signals.

The LCDs indicate elevation information by applying both graphical symbols (proportionally growing or shrinking arrows plus center bar) and numerals. While the graphics visualizes high, low or on-grade position the numerals display the distance to on-grade position.

Accuracy levels, units of measure, sound levels, and various other user options are selectable to meet a variety of job requirements.

METOR LE was specifically designed for use in harsh construction environments. Strobe rejection technology, overmolded housings, recessed windows, waterproof design and durability are incorporated into every AndroTec METOR LE.

A general-purpose clamp is included and serves to mount the detector on various grade rods and staffs. A secondary offset mounting location provides additional versatility in certain applications. A patented reversible wedge on the clamp allows sure grip mounting to round, oval, square, and rectangular rods, as well as various sizes of wooden staffs.

3 Front View

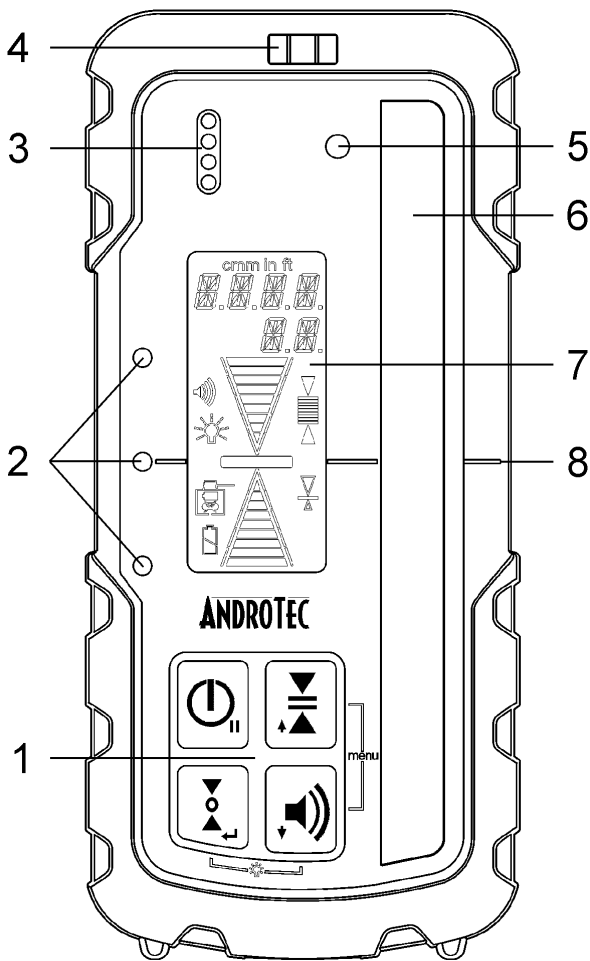

1 - Keypad: Power, accuracy, memory and volume keys. Refer to page 7.

2 - LEDs: Easy to see LEDs show position of METOR relative to the laser beam. Green for on-grade position, Red for high, and Blue for low.

3 - Beeper: Fast beeps indicates too high, lower to get to on-grade. Continuous signal is on-grade. Slow beeps is too low; raise to get to on-grade.

4 - Bubble Vial: Helps to keep METOR level for accurate readings.

5 - Anti-strobe-sensor: Detects strobe lights and rejects their input on laser reception.

6 - X²L sensor: Window must be directed towards laser.

7 - Display: Shows elevation information, receiver settings and status. Refer to page 9.

8 - On-grade mark (for center on-grade position)

4 Rear View

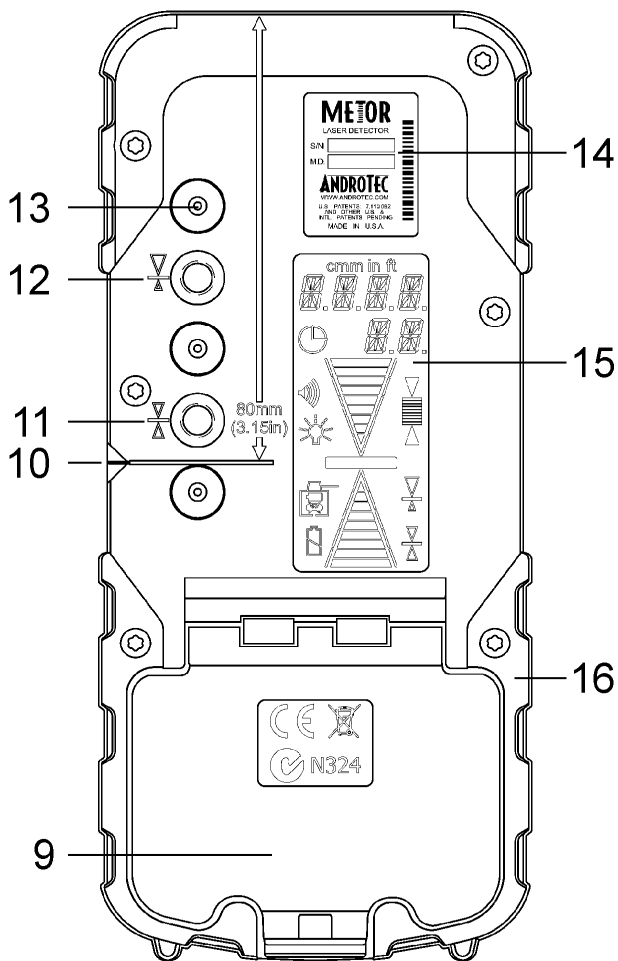

9 - Battery door and latch: Waterproof housing holds two "AA" batteries.

10 - Marking notch for center on-grade position. Top of detector is 80mm from marking notch.

11 - Captive screw thread - for center on-grade position.

12 - Captive screw thread - for offset on-grade position. Refer to page 12.

13 - Clamp guides: Dimples align rod clamp.

14 - ID label with serial number

15 - Display: Refer to page 9.

16 - Rubber over mold: Protects the receiver from accidental drops.

5 Installing the Batteries

1. Open the battery door using a coin or similar pry device to release the battery door tab.
2. Insert two AA batteries noting the plus (+) and minus (-) diagrams inside the battery housing.

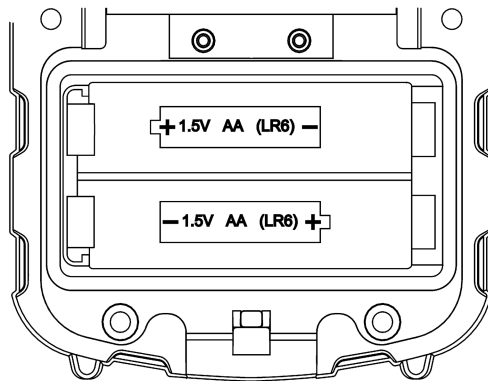

3. Close the battery door. Push down until it "clicks" into the shut position.

6 Keypad

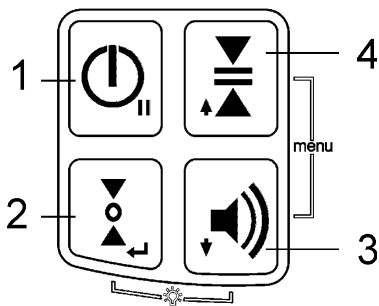

1 - Power key: Press the power key to turn power on. All LEDs, the LCD and the beeper will come on momentarily. 'CAL' will be displayed and LEDs sequenced as the unit goes through a self-calibrating procedure for approximately three seconds.

NOTE: Do not power up the unit in a laser beam or strobe. Otherwise, the unit will revert to the previous calibration and 'E200' is displayed.

Press and hold the power key for 2 seconds to turn power off.

2 – Ongrade position key: You can determine any desired ongrade position (neutral point) within $\pm 30\text{mm}$ around the marking notch. Therefore you hold the ongrade position key for 2 seconds while a reading is displayed. The displayed reading will be used as new ongrade. The indicated symbol for the staggered ongrade position blinks. If you hold the key for 2 seconds while there is not displayed reading (no laser reception), the ongrade position will be reset. Switching the unit off and on will also reset the ongrade position.

3 - Volume key: Pressing the switch cycles LOW, MEDIUM, HIGH and OFF. One beep is emitted at the selected volume when changed. When sound is OFF, a single beep will signal that a laser beam has been detected.

4 - Accuracy key: Press once to numerically display current accuracy setting on the LCD. Press again while the accuracy is displayed (within one second) to change the current selection. Subsequent presses will cycle through five accuracy options (ULTRA FINE, SUPER FINE, FINE, MEDIUM, COARSE). Refer to page 19 (Specifications).

7 Secondary Key Functions

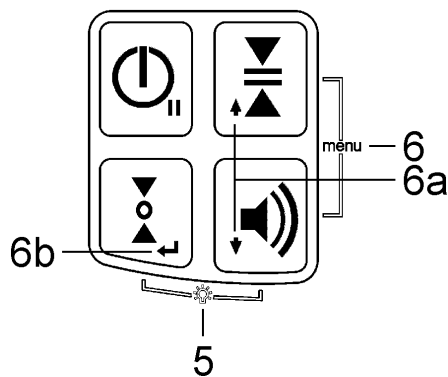

5 - LED-brightness: Pressing the memory and volume keys simultaneously enables the selection of LEDs' brightness. Press together to cycle through OFF, DIM and BRIGHT. The LEDs will display the current level of brightness selected as the switches are pressed. The light bulb symbol on the LCD will also change to display the selected setting.

6 - Menu: Pressing the accuracy and volume keys simultaneously enters the menu functions. Refer to page 14.

6a: In Menu mode, the up arrow (accuracy key) scrolls the menu up, the down arrow (volume key) scrolls the menu down.

6b: In Menu mode, the enter arrow (ongrade position key) enters or selects the available options.

8 Display

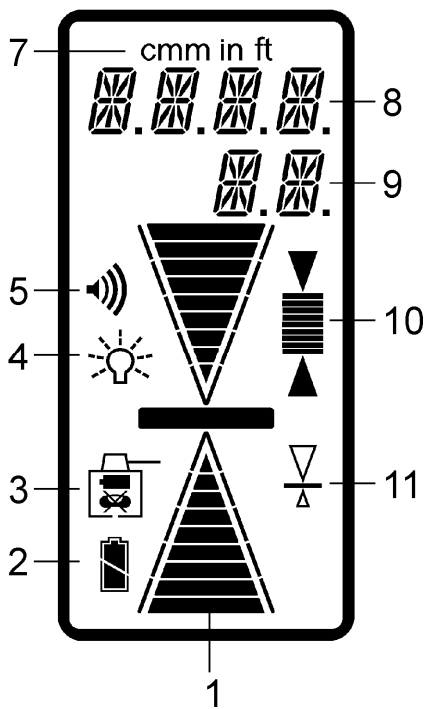

- 1 Grade indication arrows
- 2 Battery status
- 3 Laser out-of-level / laser low battery
- 4 LED brightness
- 5 Beeper volume level
- 7 Units of measure
- 8 Menu text display
- 9 Menu text display
- 10 Accuracy (Deadband) indicator
- 11 Staggered ongrade position

1 - Grade indication arrows: Ten individual levels of grade information for above and below grade. Arrow size increases as distance away from on-grade increases. Arrow bars can be selected to represent the selected deadband or can be proportional to the vertical reception range. Refer to page 15 for details. Horizontal bar indicates on-grade.

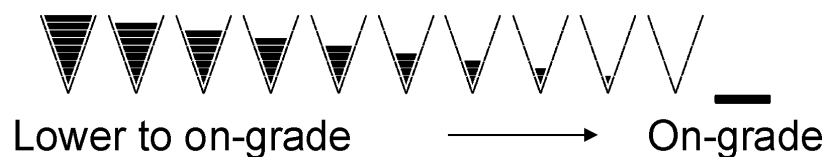

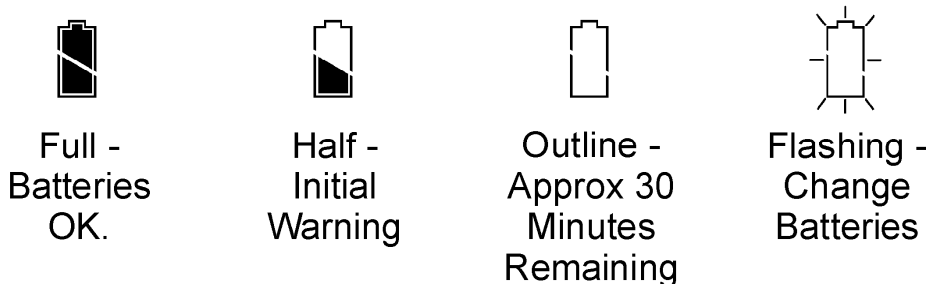

Out-of-beam display: A sequence of arrows indicates if the receiver has moved beyond the vertical reception range and will indicate in which direction to move to get back to the laser beam. Refer to page 15.

2 - Battery status: Indicates four levels of battery status. Battery life is approx. 60 hours with fresh batteries.



3 - Laser out-of-level and laser low battery warning: Some laser transmitters can signal warnings by changing the rotation speed (RPM) of the laser. When enabled, the transmitter outline is displayed with the appropriate out-of-level or low battery symbol.

 If a laser out-of-level is detected, the bubble vial symbol will blink. Additionally, the beeper will emit an alternating hi-low tone as a distinct warning, even if the beeper has been turned off. No elevation information will be displayed.

 If a laser low battery warning is detected, the battery symbol will blink. Elevation information will be displayed normally.

Refer to page 16 for details on enabling these warnings.

4 - LED Brightness: The Symbol indicates if LEDs are OFF, DIM or BRIGHT. No display indicates LEDs are OFF.

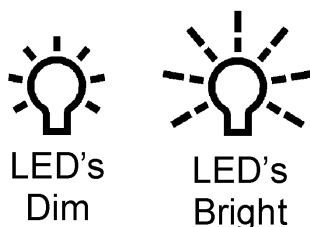

NOTE: Switching the LEDs off extends battery life.

5 - Beeper Volume: indicates if selected beeper volume is LOW, MEDIUM, LOUD or OFF. No symbol represents OFF.



Low Medium Loud

6 - Units of measure: Indicates if centimeters (cm), millimeters (mm), inches (in), or feet (ft) is selected.

7 / 8 - Menu text display: When in the MENU mode, different instrument settings can be changed. Refer to page 14 (Menu Functions) for details.

10 - Accuracy indicator: Indicates five levels of accuracy selections: ULTRA FINE, SUPER FINE, FINE, MEDIUM and COARSE. Refer to page 19 (Specifications) for the specific values for each accuracy selected. No center bar is displayed for calibration mode. Refer to page 13. This mode is intended only for calibration of rotational lasers and not for normal operation.

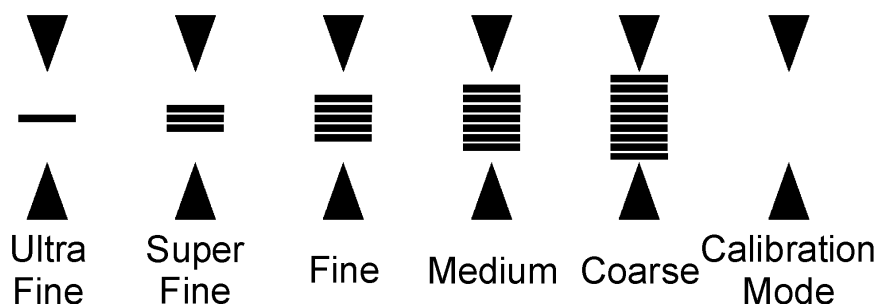

11 - Offset on-grade clamp position: METOR allows two different mounting positions for the rod clamp which are detected automatically. A corresponding symbol is displayed.

NOTE: Other clamps than the original METOR clamp can not be detected by METOR and can lead to measuring errors in offset position.

 This clamp position yields a larger range above on-grade. This is useful in applications where going below grade is not required, i.e. driving stakes down to grade.

This symbol is blinking if a user defined on-grade position is set (refer to page 7). Refer to page 18 for further information about the rod clamp.

9 Advanced Functions

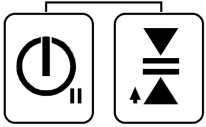

Calibration Mode: Pressing the power and accuracy keys together when the unit is off enables entry into a laser calibration accuracy mode. This accuracy is designed to be used when calibrating a laser. It is not recommended for field use.

Calibration mode will be confirmed on the LCD by the accuracy indicators without the on-grade bar.

Press the accuracy key or cycle power to exit the calibration mode.

10 Menu Functions

NOTE: The menu functions can be used to edit various options. For most applications the factory defaults are the best choice. We recommend to change settings only in special applications.

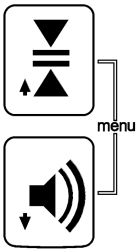

The menu screen is accessed by pressing the accuracy and volume keys together for approximately two seconds. 'MENU' will appear in the numeric display area. After two seconds the first line displays the menu function. The second line is the current setting for that function. The remainder of the LCD will be clear. No elevation information will be displayed while in the menu screens.

Menu items are selected by scrolling up or down with the accuracy and the volume keys, indicated by the small blue arrows (↑↓).



Menu items are entered by pressing the ongrade position key (blue enter symbol ↵). Once entered, the current setting will blink. To change the current setting, use the blue arrows to scroll through the options for that function. Press the blue enter arrow (↵) to confirm the current selection.

To exit the menu scroll to 'EXIT' and press enter. Alternatively, the power key can be used to back up one step or to exit the menu.

SENS - Sensitivity (LO / MD / HI): Selects reception sensitivity to laser and other light sources.

LO (Low) is used if outside sources are disturbing elevation readings.

MD (Medium) is used for most applications and is default setting.

HI (High) can be used when working with a weak laser beam or if the beam needs to be picked at very long distances. **NOTE:** Refer to the laser's specifications for accuracy and distance information.

AVG - Numeric and Arrow Averaging (LO / MD / HI): Averages laser beam strikes to improve arrow display performance at long distances. Averaging is also affected by laser RPM and accuracy setting.

LO (Low) uses minimum averaging to display laser strikes.

MD (Medium) is default setting and used for most applications.

HI (High) can be used in windy conditions, when the laser beam may be unstable, or when working at long distances.

NOTE: Refer to the laser's specifications for accuracy and distance information.

UNIT - Units of Measure: Centimeters (cm), millimeters (mm), inches (in) or feet (ft). Used for accuracy indication. Default is mm.

ARRW - Arrow Display (DB / PR): Adjusts how the off-grade arrow and bars are displayed. Default is DB.

DB (Deadband): each bar represents the deadband or accuracy setting. **NOTE:** For larger deadbands, not all bars may be displayed.

PR (Proportional): Each bar represents the available vertical reception range divided by the number of segments.

O.O.B - Out-of-Beam Display (ON / OF): When ON a sequence of arrows is displayed that indicates when the receiver has moved beyond the vertical laser reception range. The sequence will indicate which direction to move to get back in the laser beam. The display remains on for approximately 25 seconds. Default setting is OF.

GRD.A. - Grade Alarm (ON / OF): Special application function that when turned ON, disables the audible signal when on-grade. When moved out of the on-grade deadband, the beeper activates as normal. Default is OFF (OF).

A.S.O. - Automatic Shut Off (OF / 0.5 / 8): Selects automatic shutoff time from last laser strike.

OF: Automatic shutoff turned Off.

0.5: 30 minute shutoff. Factory setting.

8: 8 hour shutoff.

TX.O.L. - Transmitter Out-of-Level (OF / 2.3 / 2.7 / 3.3 / 5.0 / 6.7): Special Application used with transmitters which communicate to the receiver that the laser is out of level. The lasers change their rotating speed when they are out of level. When enabled, the receiver senses this change and alerts the user. Grade display information is disabled when activated. Factory setting is OFF (OF).

TX.L.B. - Transmitter Low Battery (OF / 2.3 / 2.7 / 3.3 / 5.0 / 6.7): Special Application used with transmitters which communicate to the receiver that the laser has a low battery by changing their rotating speed. When enabled, the receiver senses this change and alerts the user to a laser low battery condition. Default is OFF (OF). Refer to the above table on page 19 for RPM equivalents. Factory setting is OFF (OF).

INFO - Information (RPS / VER / MODL / S/N): The symbol "➤" indicates a sub menu. Press the Memory key to enter (↵).

RPS: Displays laser Revolutions Per Second for current laser strikes. **NOTE:** Refer to page 19 for RPM equivalents.

VER: Displays software version

MODL: Displays model information

S/N: Displays serial number

NOTE: The menu settings will be retained even when the unit is switched off.

11 Rod Clamp

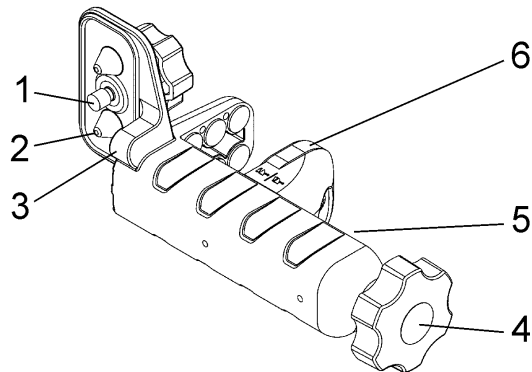

1 - Captive Rod Clamp Screw attaches to the back of detector.

2 - Alignment Points: Help secure and align rod clamp.

3 - Magnet: Allows METOR to detect which clamp position is used.

4 - Clamping Screw Knob: Secures clamp to rods by moving the traveling jaw.

5 - Reference Bar: Top of bar is aligned with the detector's on-grade location for both standard center on-grade and offset on-grade clamp locations.

6 - Traveling Jaw with reversible face: Slanted face is used to tightly grip round and oval rods. Flat face is used to grip rectangular and square rods.

7 - Optional Bubble Vial Kit: Helps to keep rods vertical when taking rod readings.



Rectangular
Rods



Oval / Round
Rods

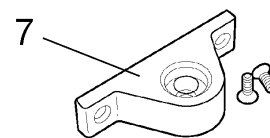

NOTE: Always use original METOR rod clamps! Other clamps can not be detected by METOR and can lead to measuring errors in offset position.

12 Specifications

Working radius: 1 m – 300 m (Laser dependent)
Sensor: X²L-Sensor, Length 127 mm
Numeric Readout Height: 102 mm

Accuracy (Deadband):	In	ft	mm	cm
Ultra Fine	0.02	0.002	0.5	0.05
Super Fine	0.05	0.005	1.0	0.10
Fine	0.10	0.010	2.0	0.20
Medium	0.20	0.020	5.0	0.50
Coarse	0.50	0.050	10.0	1.00
Calibration Mode	0.01	0.001	0.1	0.01

Reception Angle: $\pm 45^\circ$
Detectable Spectrum: 610 nm ... 790 nm
Beeper-Volumes:
Loud 110 dBA
Medium 95 dBA
Low 65 dBA

LED Grade Indicators:
Green: On-grade,
Red: above
Blue: below

Power Supply: 2 x 1.5 V Batteries, Size AA
Battery Life: Up to 60 hours
Automatic Shut Off: Selectable: 30 min., 8 h, Off
Environmental: Waterproof, Dustproof to IP67
Weight without clamp: 370 g
Dimensions without clamp: 168 x 76 x 36 mm
Operations Temp: -20°C ... +60°C
Storage Temp: -40°C ... +70°C

Conversion Table	RPS	RPM
Laser Rotation:	6.7	400
	5.0	300
	3.3	200
	2.7	160
	2.3	140

Specifications subject to change without notice.

13 Warranty

AndroTec METOR and clamp are warranted to be free of defects in material and workmanship according to the statutory warranty regulations.

The user of the product is expected to follow all operating, maintenance and care instructions. Any evidence of misuse, alteration, or an attempt to repair products by unauthorized personnel, or use of parts other than those provided by AndroTec GmbH automatically voids the warranty.

In addition AndroTec GmbH grants an extended warranty for a period of three years if within six weeks from the date of purchase the warranty registration card is filled out and returned to AndroTec or the product is registered via Internet at www.androtec.com. Please make sure that the registration is filled out properly and on file with AndroTec GmbH.

This warranty period is thirty-six months from the date the new product is delivered from the dealer to the purchaser or is put into service by a dealer as a demonstration unit or rental unit. Competitor purchased and tested units are excluded from this warranty.

AndroTec GmbH may choose to repair or replace, at its discretion, any METOR, in the event of a failure for any reason, during the warranty period. In case of a warranty claim, return the product and a proof of purchase to the factory.

AndroTec's liability under this warranty is limited to repairing or replacing any product returned to its factory for that purpose. The foregoing states the entire liability of AndroTec GmbH regarding the purchase and use of its product and they shall not be held responsible for any consequential loss or damage of any kind. This warranty is in lieu of all other warranties, expressed or implied, and constitutes all of AndroTec GmbH liability with respect to merchandise sold by it.

Warranty is strictly related to repair or substitution of defective parts according to AndroTec's discretion. The warranty does not cover any other damage that may occur directly or indirectly using defective parts.

14 Maintenance and Safety

CLEANING: Do not wipe dust or dirt off the detector reception window or display windows with a dry cloth or other abrasive material as scratching could occur, reducing visibility through these windows. A soft cloth and mild soap and water are effective. The unit may be submerged under water or sprayed with a low pressure hose if necessary. Do not use any other fluids than water as they may attack polymer components.

TRANSPORT: Use the original carton or a laser instrument case to transport the detector.

STORAGE: If the detector will not be used for a month or more, it is recommended to remove the batteries.

BATTERIES: It is recommended to use only high quality alkaline or rechargeable batteries.

INTENDED USES OF DETECTOR: METOR is designed and suitable for detecting a rotating laser beam.

PROHIBITED USES:

- Operation other than the intended uses
- Opening the detector, except the battery compartment
- Modification or conversion of the detector
- Use of non-original METOR accessories
- Operation without instruction

PRECAUTIONS: The person in charge of the detector must have read and understood the instructions in this manual and ensure other users do also.

Periodically carry out test measurements, particularly after the detector has been subjected to abnormal use (e.g. accidental drops) and before and after important measurements.

15 Disposal

Disposal of batteries via domestic waste is prohibited! The user is liable to recycle worn batteries. In many countries, batteries can be returned free of charge to communal collecting points or battery dealers.

Dispose of the detector which can no longer be used (irreparable) in accordance with the valid legal regulations.

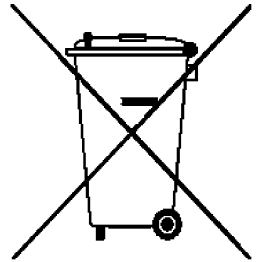

This product shall not be treated as household waste.

Instead it shall be handed over to the applicable collection point for the recycling of electrical and electronic equipment. Alternatively, please ship the detector for proper disposal to AndroTec clearly stating "WEEE / Disposal" on the packaging. The customer is responsible for the costs of transport to AndroTec.

By ensuring this product is disposed of correctly, you will help prevent potential negative consequences for the environment and human health, which could otherwise be caused by inappropriate waste handling of this product. The recycling of materials will help to conserve the natural resources.

WEEE registration number of manufacturer: DE37015608

16 CE Declaration of Conformity

Application of Council Directive 89/336/EEC

Name and Address of Manufacturer:

AndroTec GmbH
Hauptstraße 186
D-67714 Waldfishbach-Burgalben
Bundesrepublik Deutschland
<http://www.androtec.de>

Model number:

AndroTec METOR MTR-125 LE

Equipment Type / Environment:

ITE, commercial, light industrial

Harmonized Standards Applied:

Electromagnetic Compatibility (EMC)
EN 61326:1997 +A1:1998 +A2:2001 +A3:2003 Class B Annex A,
EN 55022:1998 +A1:2000 +A2:2003,
EN 61000-4-2:1995; EN 61000-4-3:1996; EN61000-4-8:1993,

We herewith declare, in exclusive responsibility, that the instrument conforms to the above mentioned directive including their amendments up to the date below.

Waldfishbach-Burgalben, 1. November 2009



Dr.-Ing. Klaus-Werner Jörg
(Managing Director)

ANDROTEC

Get to the point with us ●

AndroTec GmbH
Hauptstraße 186
D-67714 Waldfischbach-Burgalben
Germany

Phone +49 (0) 6333-27 55 0

Fax +49 (0) 6333-27 55 22

E-mail info@androtec.de

Internet www.androtec.de